



Audi e-tron
Audi e-tron Sportback

Future is an attitude

Contents

Audi e-tron	Electric Mobility	01
	Overview	02
Performance and Motor	Performance	03
	Motor	05
	Performance Features	08
	Body Style	10
Equipment and Aesthetics	Exterior	11
	Exterior Features	13
	Digital LED Matrix Headlight**	17
	Interior	19
	Interior Features	21
	Infotainment	24
	Infotainment Features	26
	Efficiency And Charging	28
	Charging Features	30
	Charging Capacity	32
	Safety Features	34
	e-tron Hub	37
Colour and Styling	Exterior Colour Options	41
	Interior Colour Options	42
Technical Information	Technical Data	43



The power of electric mobility

The e-tron name describes Audi vehicles that are wholly driven by electric power, featuring plug-in and fast-charging convenience, advanced energy recuperation whilst driving, and of course, zero emissions. With sophisticated batteries, forward-thinking navigation systems that build charging into your journey and innovative driving systems for safety and control, an electrified Audi is a leap into smarter driving. Which is why, the name Audi e-tron is now synonymous with electric mobility.



The future is electric

With progress comes evolution. And the new Audi e-tron is the pinnacle of that evolution. This isn't just another car, it's the beginning of a new era - the era of electric. It's a car from the future, for the future.



Performance

Image for representation purpose only. Please contact your nearest Audi authorized e-tron dealer for further details.



Electrifying performance

Powered by two incredibly dynamic electric motors in the front and rear, the Audi e-tron is a completely novel driving experience. This electric SUV promises an impressive driving experience with its progressive steering and electric all-wheel drive system which provides for optimal traction and handling in all driving situations. You've never driven an Audi like this before.

Audi e-tron 50



Power
230 kW/313 HP



Torque
540 Nm



Acceleration
6.8 sec
(0 to 100 km/h)



Range
(WLTP combined)*
264-379 km



Battery
71 kWh

*This maximum value is obtained in efficiency driving mode on 48.26 cm tires with air conditioning and heating switched-off within city conditions at a temperature above 5°C as per WLTP certificate. Driving range may vary for other driving conditions and environment factors.

Audi e-tron 55



Power
300 kW/408 HP



Torque
664 Nm



Acceleration
5.7 sec
(0 to 100 km/h)



Range
(WLTP combined)*
359-484 km



Battery
95 kWh

*This maximum value is obtained in efficiency driving mode on 48.26 cm tires with air conditioning and heating switched-off within city conditions at a temperature above 5°C as per WLTP certificate. Driving range may vary for other driving conditions and environment factors.

Audi e-tron 55 Sportback



Power
300 kW/408 HP



Torque
664 Nm



Acceleration
5.7 sec
(0 to 100 km/h)



Range
(WLTP combined)*
359-484 km



Battery
95 kWh

*This maximum value is obtained in efficiency driving mode on 48.26 cm tires with air conditioning and heating switched-off within city conditions at a temperature above 5°C as per WLTP certificate. Driving range may vary for other driving conditions and environment factors.

Performance Features



> Front And Rear Electric Motors

Two electric motors in the front and rear means that the e-tron comes with effortless power. An electric boost in the e-tron 55 provides a surge in power to improve the acceleration and can be deactivated via a kick-down pedal.



> Progressive Steering System

Progressive steering is a standard feature in the e-tron that enhances handling dynamics and ride comfort. This steering assistance system provides more direct steering and reduces steering effort which makes your e-tron more responsive in the city for easy parking and maneuvering, and more agile and precise on open roads.



> e-quattro

The future of quattro is now electronic as well. The all-new, updated electronic four-wheel drive features 3 quattro modes - Auto, Dynamic, and Off-road. The front axle activates predictively as per the situation.



> Audi Drive Select

The Audi Drive Select comes pre-loaded with 7 different modes that allow you to adjust the vehicle's characteristics by adapting the steering assistance, engine characteristics and adaptive air suspension.



> Adaptive Air Suspension

The adaptive air suspension system sets the height of the body at different levels depending on the vehicle's speed and the driver's request. This means that the e-tron intuitively increases or decreases its ground clearance, thereby providing supreme ride comfort and sporty handling.

Body Style

The new Audi e-tron and Audi e-tron Sportback are each uniquely different.



Audi e-tron:
A dapper, broad SUV with a well-defined straight roof.



Audi e-tron Sportback:
An athletic SUV with a robust, sloping roof line.



Exterior



Elegantly electric

The new Audi e-tron is straight from the future. From the platinum grey single-frame grille to its modern taillights, it creates an era-defining design aesthetic. The e-tron's four horizontal struts that have been integrated in the standard LED headlights add to its sleek road presence and its progressive, dynamic design makes sure that it turns heads wherever it goes.

Exterior Features



> Digital Matrix LED Headlights**

The new Audi Matrix LED headlights are based on the cutting-edge digital micromirror device technology. This revolutionary technology opens up new possibilities for adaptive light distribution and light assistance through the direct projection of high-resolution light images. It automatically adjusts the orientation of the light, thereby dimming and illuminating the road ahead as needed. The e-tron also offers 5 pre-set projection modes that can be selected from the top MMI display.

> Door Entrance LED Projector Lights In Front And Rear

A simple, yet elegant feature that projects the e-tron logo on the ground using LED technology when you open the front or rear side doors.

> Panoramic Glass Sunroof

The electronically operated panoramic glass sunroof not only provides you with a beautiful, clear view of the sky, but also integrates well with the aesthetic of the car's design.



> **Orange Brake Callipers**

Brake callipers painted in dynamic orange visualise the high-voltage technology of the Audi e-tron.



> **Acoustic Sound Generator**

This system generates a futuristic sound whenever the e-tron is put in drive or reverse gear, through external speakers, making the streets safer for pedestrians.



> **Comfort Key With Gesture-based Lid Operation**

Unlocking the e-tron is now easier with the convenience of the comfort key. You simply need to carry the comfort key with you and the system lets you unlock your vehicle. And when your hands are full, a simple foot gesture can open, and close, your e-tron's boot lid with ease.



> **Soft Door Closing***

The power-assisted door closing function gently pulls the doors in and closes them soundlessly.



> **e-tron Badges On Charging Flaps**

Charging the e-tron becomes easier with these e-tron badges on the charging flaps for easy identification and access.



> **50.8 cm Alloy Wheels With 5 arm Dynamic Style In Graphite Gray**

Accessorise all aspects of your Audi e-tron, including the rims, with the 50.8 cm alloy wheels with a 5 arm dynamic style, available in graphite gray.



> **Platinum Grey Single Frame Grille**

The platinum grey single frame grille in the front gives your Audi e-tron a sleek, stylish look, so that your car makes its presence felt wherever it goes.



> **Rear Lights With Continuous LED Strips**

This aesthetic feature accentuates the shape of your e-tron. The continuous LED strips in the rear make the design more dynamic, and your vehicle more visually stunning.





Digital LED Matrix Headlight**

Light up the night with the new Audi Matrix LED headlights. These headlights are based on the cutting-edge digital micromirror device technology, which opens new possibilities for adaptive light distribution and light assistance through the direct projection of high-resolution light images.

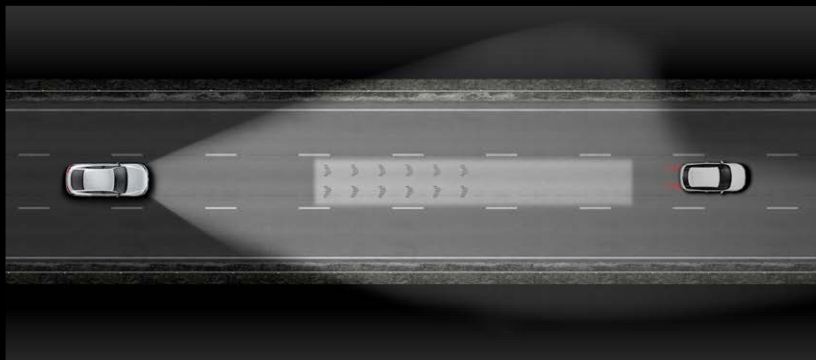

> Light-assisted Lane Guidance

Illuminate the lane ahead with a bright carpet of light with the help of the light-assisted lane guidance system. This assistance system works within system limits to support the driver.

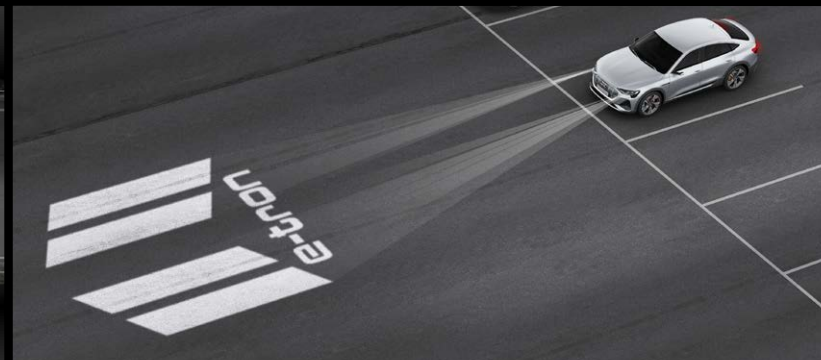

> Extended Lighting With Dynamic Projections

The extended light staging can not only be experienced in the signature elements of the headlights and rear lights, but also as a dynamic projection in front of the vehicle, with five dynamic projections available to be conveniently selected via the MMI.





Interior

Image for representation purpose only. Please contact your nearest Audi authorized e-tron dealer for further details.



Charged to recharge

Design and technology come together to create the most luxurious in-cabin experience. In true Audi style, every inch of it feels purposeful and premium. A generous arc envelops the cascading MMI touch response instrument panel. With soothing ambient and contour lighting, 4-zone automatic air conditioning, and a top-of-the-line Bang and Olufsen sound system, the interiors are designed to recharge you on the go.

Interior Features



> Wraparound Dash Panel

The wraparound dash panel gracefully traces the arc of the car, encompassing the instrument panel and harmoniously integrating the hood above the Audi virtual cockpit.



> Contour And Ambient Lighting Package With 30 Colour Options**

The contour and ambient lighting package comes with 6 predefined colour profiles and an additional interactive, custom colour profile which is controlled via the Audi drive select modes. You also get to choose from 30 colour options to personalise your car's interiors.



> Air Quality Package**

The air quality package uses an air-ioniser to reduce harmful particles and germs from the air in the cabin, thereby improving its quality. It comes with two distinct fragrances and 4 different intensities.



> 4-zone Climate Control System

A standard feature of the Audi e-tron, the 4-zone climate control system is an air conditioning system that has separately adjustable temperature and air distribution settings for the left and right-hand sides as well as front and rear of the car, along with a rear touchscreen display.



> 360-degree Camera System**

Four wide-angle 360-degree cameras provide a range of different views as you manoeuvre your e-tron. These cameras cover the area immediately around your vehicle and can be controlled via the top MMI Display.



> Twin-spoke Leather Steering Wheel With Multifunction And Shift Paddles

This uniquely crafted steering wheel feels just right in your hands. Its progressive and exclusive design with an aluminium look integrates seamlessly with the interiors. The shift paddles allow you to switch manually between recuperation stages.



> Cruise Control With Speed Limiter Function

The cruise control function helps you maintain a set speed for your e-tron by automatically braking or accelerating the car as and when needed. With the speed limiter function, you can limit your e-tron from going over a set speed. This is especially useful for roads with a speed limit.



> Cabin Silence

The body of the e-tron has been optimised for comfort when it comes to vibration and noise. Sound absorbing and insulating materials reduce sound penetration in the passenger compartment while advanced aeroacoustics further reduce background noise.





Infotainment

Image for representation purpose only. Please contact your nearest Audi authorized e-tron dealer for further details.



Connect to the future

The all-new Audi e-tron is a technological marvel in more ways than one. Combining the best of automotive technology with the best-in-class infotainment features, such as the Audi Virtual Cockpit, MMI Navigation Plus with MMI touch response and other such features, make the Audi e-tron full of endless possibilities.

Infotainment Features



> Audi Virtual Cockpit/Audi Virtual Cockpit Plus*

Innovative, adaptive, and intuitive, the Audi Virtual Cockpit is a 31.24 cm fully digital instrument cluster for flexible, on-demand display of relevant information tailored to fit the driver's needs. From monitoring electric range to displaying maps, to connecting with the radio and media services, everything is made possible here.



> MMI Navigation Plus With MMI Touch Response

A high-resolution 25.65 cm colour display, the MMI navigation plus system is an intuitive touch-based system that provides haptic feedback and a host of functions, ranging from navigation on a 3D Map to other control functions. This feature also includes a free text and search system that functions as a search engine, delivering responses within a few short seconds.



> **Bang and Olufsen Premium Sound System****

The Bang and Olufsen premium sound system is an optional feature, but one that you definitely need in your e-tron. With a 705 W output, 3D sound system, and 16 speakers working in conjunction with the low noise electric drive, your music will soundtrack your journey.

> **Audi Phone Box with Wireless Charging**

The Audi phone box with wireless charging is an important feature for those on the go. It optimises phone calls in the vehicle, thanks to its improved reception and call quality along with wireless charging.

> **Head-up Display***

The intuitive head-up display projects information such as vehicle speed, warning messages, navigation, etc. directly to the driver's field of vision. It provides a high-contrast, multi-coloured display with reduced distraction from the road, and can also be adjusted to your preferred height.



Efficiency And Charging



The future created today

The future is green, the future is sustainable. At Audi, we believe in creating better technology for a better tomorrow, today. Exactly why the e-tron is a pioneer when it comes to electric cars.

Charging Features



> Range Mode

The range mode monitors and controls the activity of your e-tron, drastically increasing the range of your car.



> e-tron Compact Charging System

Designed for charging at domestic sockets, this system comprises an operating unit, a vehicle connecting cable, and two different mains cables with domestic and industrial plugs. The e-tron compact charging system has a charging power capacity of up to 11 kW. It comes with a wall bracket to safely mount your e-tron charging system on the wall.



> Charging Facility On Both Sides

Recharging your e-tron becomes easier and convenient when you have charging slots available on both sides of the car. Park your vehicle in any direction to charge it.



> Thermal Management System

The e-tron's thermal management system is responsible for heating up and cooling down the battery in response to the ambient temperature, optimising battery longevity and ensuring reproducible performance. The thermal management system makes DC charging up to 150 kW possible due to its intelligent cooling capabilities.



> Recuperation

With its ground-breaking recuperation technology, the new Audi e-tron converts kinetic energy into electrical energy. 3 selectable recuperation stages allow you to adapt recuperation to your individual requirements, with each stage having a different level of deceleration that lets you recover different amounts of energy. This system can be controlled manually using shift paddles too.

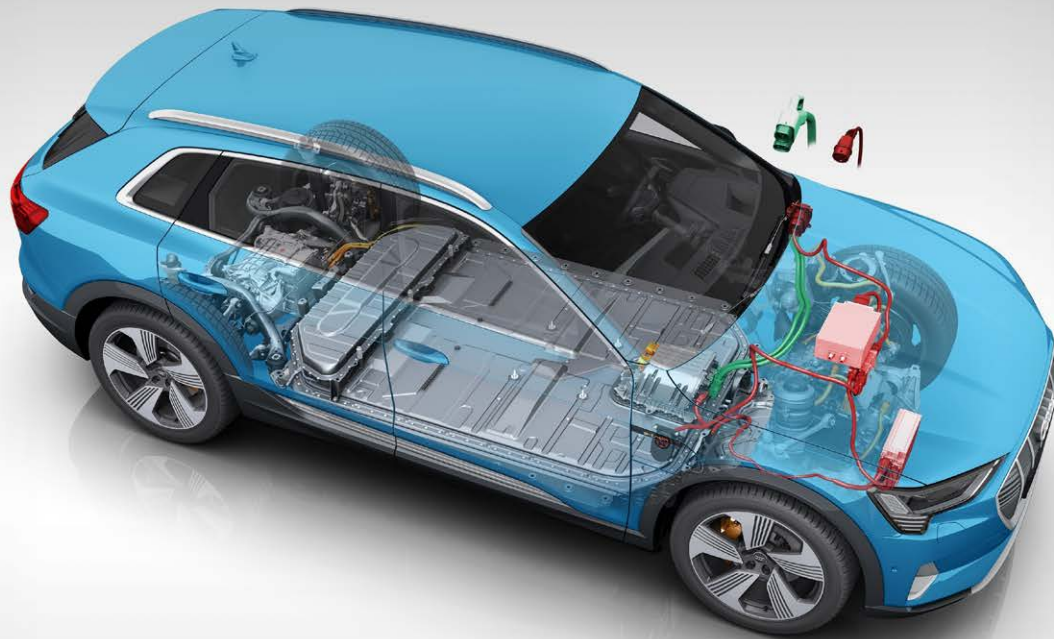

Charging Capacity

The charging process is central to the everyday usability of your Audi e-tron. With capacities ranging from 11 kW AC to 150 kW DC, charging your car is now faster than ever. Less charge time means more road time.



11 kW
AC charging

The Audi e-tron can be charged at home or at the office using the 11 kW AC compact charging system. Overnight charging can set you up with a full battery for the next day.



22 kW
AC charging

The Audi e-tron also provides an optional 22 kW on-board charger, that can be used at public AC charging stations and select Audi dealerships. This cuts down your charging time by half, when compared to the 11 kW AC charger.



150 kW
DC charging

Leave your charging concerns at home when driving long distances. The Audi e-tron can be charged with up to 150 kW at high-output DC charging stations. This allows you to charge up 80% of your battery in just 30 mins.



Safety Features



The future of safety

The car from the future also brings with it the future of safety. The many intuitive safety features of the Audi e-tron proactively sense and avoid danger rather than just react to it. So that you can always be safe and comfortable.



> 8 Full-size Airbags

The Audi e-tron comes with 8 full-size airbags. These include the front airbags, front and rear side airbags and head airbag. Illuminated seat belt buckles provide additional convenience for the occupants and enhance the interior with discreet and high-quality illumination.



> Audi Pre-sense Basic

This intuitive feature initiates preventive protection measures in critical driving situations such as emergency braking or handling at the absolute limits of performance. It involves tensioning the front seat belts and optimising seat position, closing the windows and the panoramic glass sunroof to cover all bases.



> Protection And Crash Safety

Battery housing and crash structures secure the battery pack and ensure a high degree of crash safety in critical situations.



e-tron Hub



Tap to the future

Getting to know your Audi e-tron just got a whole lot easier. The e-tron hub is a special tab available on the Audi Connect app that guides you on a range of functions and features of your e-tron. From guiding you on how to find your nearest charging station to getting to know your car better, the e-tron hub is full of endless possibilities. Audi e-tron Hub is available on the application and the website.





Ease Of Purchase

Submit a survey request for your home or office using the Audi Mobility Check under e-tron Hub to help locate the best location for your charger.



Range Calculator

Learn how to plan your trips with the range calculator.



Charging Network

Get help locating the charging stations nearest to you on a digital map.

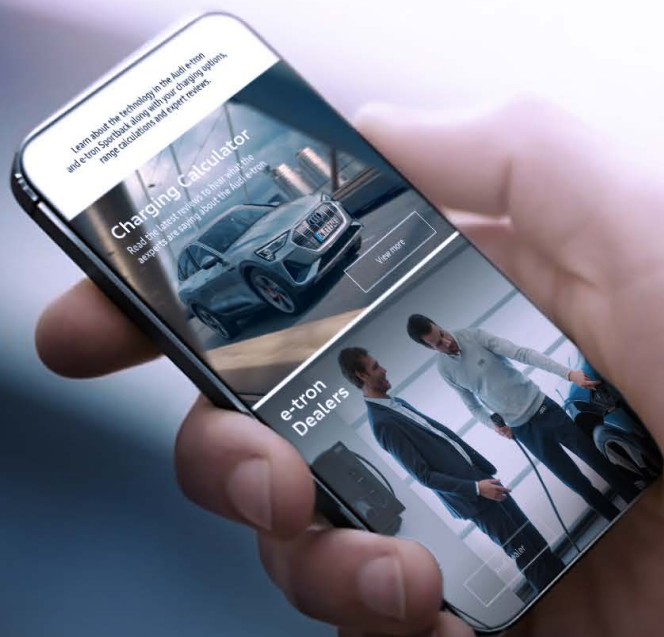

Limitless Knowledge

The e-tron hub has numerous video guides and FAQ's to answer all the questions you might have about your vehicle, right from charging systems to usage.



Savings Calculator

Quantify your car's environmental impact with this tool.



Charging Time Calculator

Get an accurate estimate on the time required to charge the car based on the capacity of the charger available.



Convenience

One-click Dedicated Road Side Assistance for e-tron on the myAudi Connect application

Exterior Colour Options

Choose the best shade for your Audi e-tron from these exterior colour options.

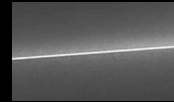

Typhoon Gray
Metallic



Siam Beige
Metallic



Plasma Blue*
Metallic



Mythos Black
Metallic



Glacier White
Metallic



Galaxy Blue
Metallic



Floret Silver
Metallic



Catalunya Red
Metallic



Navarra Blue
Metallic



Interior Colour Options

Select the best hue for the interiors
of your Audi e-tron.

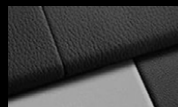

Black



Okapi Brown



Mother of Pearl Beige

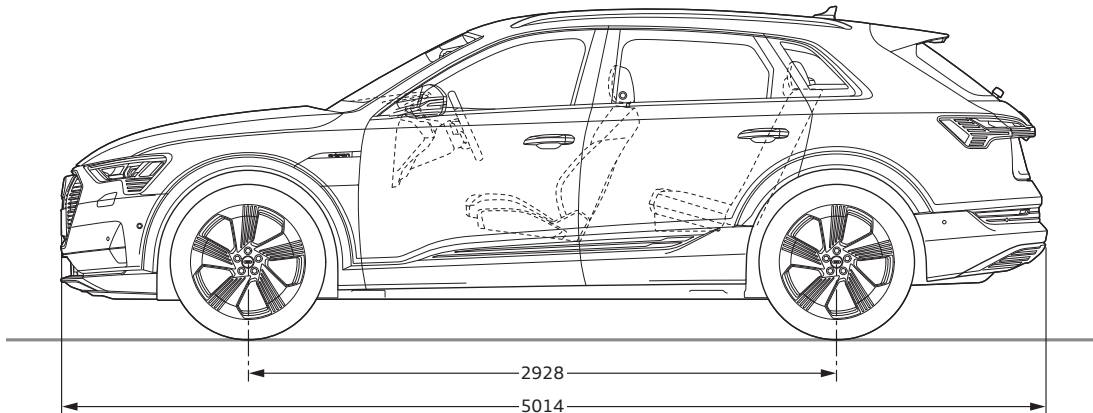
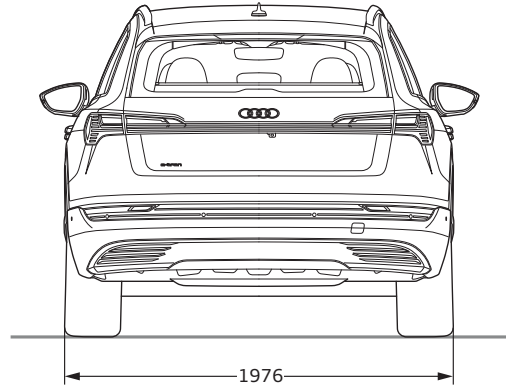
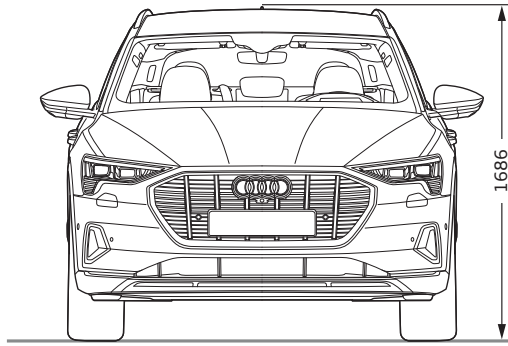

Audi e-tron 50

Motor Type
Electric motor

Max power in hp (kW)
313(230)

Max Torque in Nm
540

Drive Type
Quattro All-wheel Drive

Acceleration 0-100 km/h in sec
6.8

Gross Battery Capacity (kWh)
71

Net Battery Capacity (kWh)
64

Wheel Type/Size
50.8 cm, 5-Arm Dynamic style, Graphite Gray

Kerb Weight (kg)
2,445

Gross Weight (kg)
3,040

Top Speed (km/h)
190

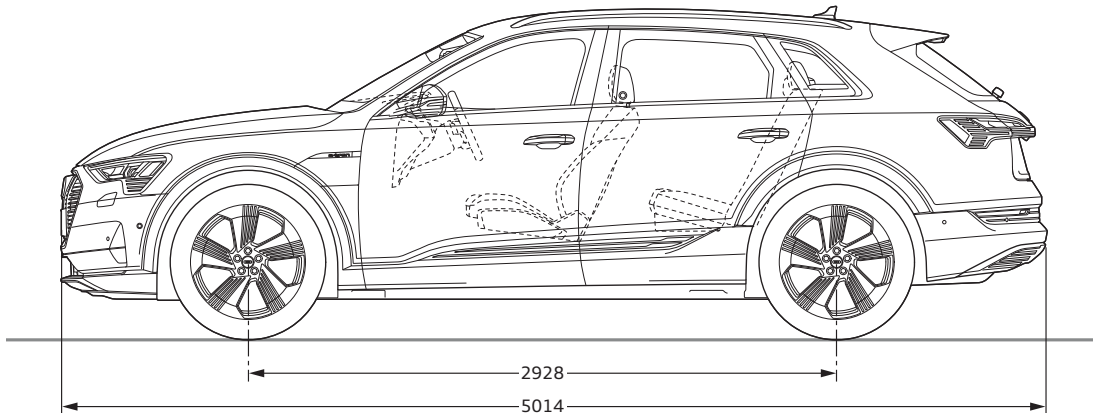
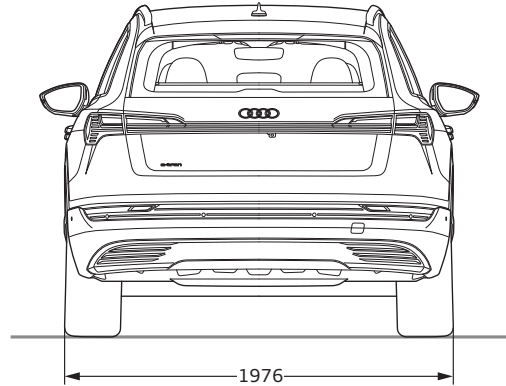
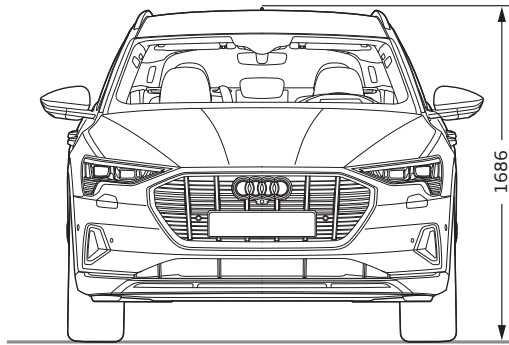

Audi e-tron 55

Motor Type
Electric motor

Max power in hp (kW)
408(300)

Max Torque in Nm
664

Drive Type
Quattro All-wheel Drive

Acceleration 0-100 km/h in sec
5.7

Gross Battery Capacity (kWh)
95

Net Battery Capacity (kWh)
86

Wheel Type/Size
50.8 cm, 5-Arm Dynamic style, Graphite Gray

Kerb Weight (kg)
2,595

Gross Weight (kg)
3,170

Top Speed (km/h)
200

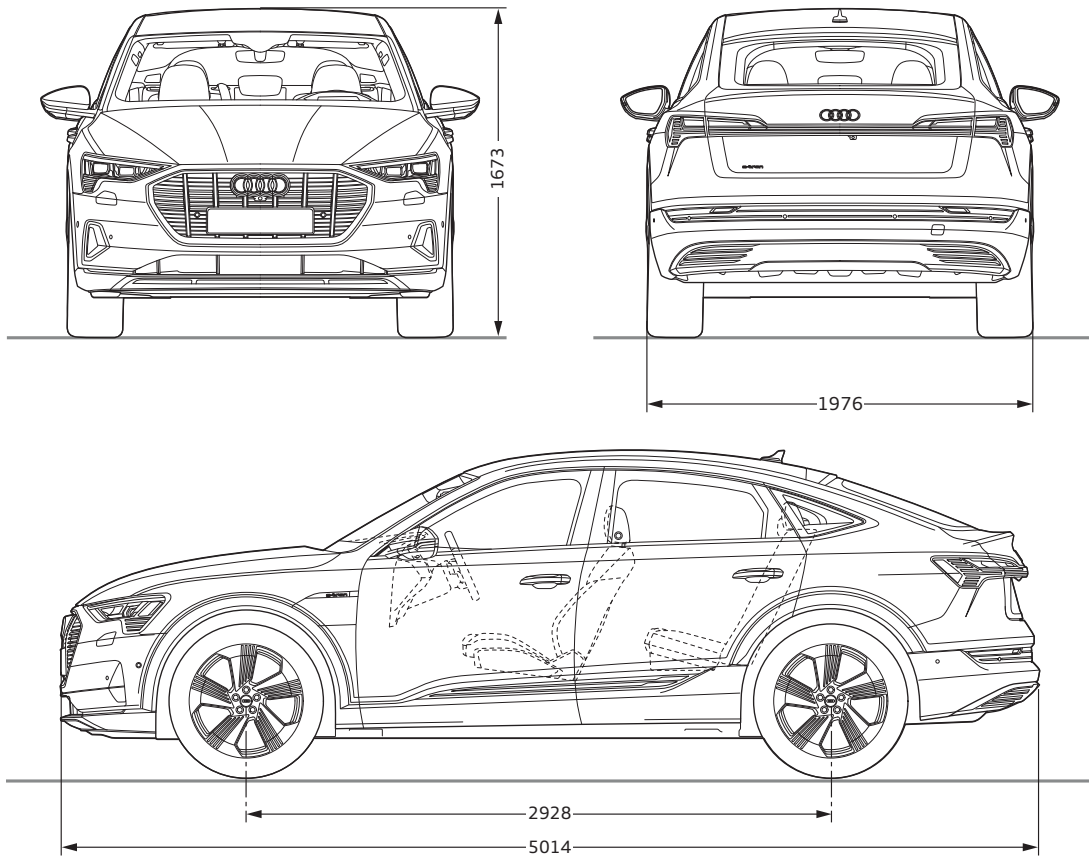

Audi e-tron 55 (Sportback)

Motor Type
Electric motor

Max power in hp (kW)
408(300)

Max Torque in Nm
664

Drive Type
Quattro All-wheel Drive

Acceleration 0-100 km/h in sec
5.7

Gross Battery Capacity (kWh)
95

Net Battery Capacity (kWh)
86

Wheel Type/Size
50.8 cm, 5-Arm Dynamic style, Graphite Gray

Kerb Weight (kg)
2,595

Gross Weight (kg)
3,170

Top Speed (km/h)
200

Audi Vorsprung durch Technik

Audi India

A division of

ŠKODA AUTO Volkswagen

India Private Limited





(formerly known as Volkswagen

India Private Limited)

Mumbai - India

CIN: U70102PN2007FTC133117

www.audi.in

© AudiIN  audiindia  audiindia  AudiIN  audiindia | [myAudi Connect](#)

The visuals are for illustration purposes only. The model, colours and equipment versions illustrated and described in this brochure as well as some of the services listed may not be currently offered in India. The model and colours of the car illustrated are subject to change without any prior notice and equipped with optional features for which an extra charge is made. Driving Range mentioned is as per WLT Certificate and subject to conditions mentioned in the brochure and shall vary with the model, driving style and external factors. Deviations from the colours and shapes shown in the illustrations may occur. Dark shade on glass is due to lighting effect. No liability is accepted for errors and printing errors. Images are clicked in countries that follow left hand drive. The right to introduce modifications is reserved. Not to be reproduced, including in part, without the written approval of AUDI AG.