



SUPERIOR BY NATURE.



For over 75 years, the Jeep® Brand has been conquering lands and hearts alike. Its unwavering heritage and dedication to discovering the unknown stands tall even today. Indelibly linked to freedom, adventure, authenticity, and passion, these core values are embodied in every Jeep® vehicle's DNA.

Introducing the Jeep® Compass Trailhawk® – an SUV that combines these core ideals with the predatory dominance of a hawk. Built to dominate every challenging terrain, its Trail Rated® badge is an affirmation of the same capability and a sign of its worldwide off-roading authority. Outfitted with coveted creature comforts and world-class 4x4 capability, your journey to owning the wild begins here.





Dual Zone Automatic Climate Control

The Dual Zone Automatic Climate Control constantly adjusts air temperature inside the cabin to create separate customised environments providing excellent comfort for all passengers.



17.78 cm (7) Premium Instrument Cluster

A state-of-the-art, reconfigurable 17.78 cm (7) wide instrument cluster displays all the essential information, helping you feel connected and secure.



Engine Stop - Start System

The Engine Stop - Start System ensures the engine intelligently turns off instantly when not in use and restarts automatically when needed. When going through heavy traffic, this feature reduces the amount of time the engine stays idle, thereby reducing fuel consumption and emissions.

PURE ADVENTURE OUTSIDE. PURE LUXURY INSIDE.

The Jeep[®] Compass Trailhawk[®] has been built with the capability to go anywhere. Its cockpit and cabin are designed to keep you comfortable everywhere, on city roads and uneven terrain. To add to it, the sporty design, handpicked leather, plush seats, and sophisticated finishes take comfort and luxury to extraordinary heights.

Plush Seats

Every aspect of the Trailhawk[®] interior is designed to give you utmost comfort. Featuring plush seats covered in signature black leather with ruby red stitching, it is a sporty yet sophisticated space.



All-black Interior with Red Accents

The whole cabin has been designed using high-grade materials in a premium black colour, accentuated with striking red finishes that give it a dynamic yet luxurious feel.





Dual Pane Panoramic Sunroof

The class-leading dual pane panoramic sunroof enhances the sense of spaciousness and floods the cabin with natural light. With its power sunshade, it lets you gaze at the skies, the stars, the moon, and even the sun, for as long as you want.

MAKE AN ENTRANCÉ. MAKE IT UNFORGETTABLE.

The Jeep® Compass Trailhawk® has an aerodynamic profile, a distinct silhouette, and an aggressive stance that make it instantly recognizable. So, no matter where you go, you're sure to turn heads. The sloping roofline and muscular arches make it look powerful, purposeful, and predatory. The Trailhawk® exudes bold confidence with its athletic styling and sweeping modern curves further highlighting its capability. Fueled by the Jeep® Brand's adventure DNA, the Trailhawk® is the most formidable and capable Jeep® Compass ever.

43.18 cm (17) Trailhawk® Alloys

The heavy-duty 43.18 cm (17) five-spoke alloy wheels are built specially for all off-road challenges and they perfectly complement the rugged personality and style of the Trailhawk®.



Hood Decal and Trailhawk® Fascia

The signature black hood decal and fascia create a bold impact and make the Jeep® Compass Trailhawk® instantly recognizable.







WORLD-CLASS CAPABILITY COMES STANDARD.

A Trail Rated® badge is not given. It's earned. Every Trail Rated® 4x4 Jeep® vehicle has succeeded against a series of grueling tests to prove its off-road capabilities on some of the toughest trails on the planet. Pushing our vehicles as far as they can go is part of the Jeep® Brand DNA. As long as we strive for ground-breaking capability and you pursue exhilarating adventures, Trail Rated® Jeep® vehicles will continue to be tested on everything you may encounter.

The tests that push the boundaries of capability fall in five performance categories: Traction, Water Fording, Maneuverability, Articulation, and Ground Clearance. The rating in each performance category defines the ultimate breadth of capability of the Jeep® vehicle.

The Jeep® Compass Trailhawk® has earned the Trail Rated® badge – a sure sign that you can take your Jeep® vehicle to the end of the earth and back. In other words, unparalleled 4x4 capability comes standard with the world-class Jeep® Compass Trailhawk®.



Traction

Crawl Ratio - 20:1



Water Fording

Water Depth Capability - 48.3 cm



Maneuverability

Wheelbase - 2636 mm
Overall Length - 4398 mm
Turning Radius - 5700 mm



Articulation

Ramp Travel Index - 321



Ground Clearance

Approach Angle - 26.5 degrees
Breakover Angle - 21.2 degrees
Departure Angle - 31.6 degrees

2.0L Multijet II Turbo Diesel Engine

The Jeep Compass Trailhawk® comes with a BSVI compliant 2.0L Multijet II Turbo Diesel engine that puts you in charge of an impressive 170 HP and 350 Nm of torque. These friction-reduced engines are specifically engineered to enhance performance, fuel efficiency, and lower emissions.



RUNS ON FUEL. THRIVES ON ADVENTURE.

The Jeep Compass Trailhawk® translates the predatory capability of hawks - on the road and off it. Under the hood, it packs a powerful engine that makes you truly unstoppable on adrenaline-packed off-road adventures. The intelligently engineered engine, paired with a 9-speed automatic gearbox, gives the Jeep Compass Trailhawk® a perfect blend of brawn and brain to thrive on every adventure you go on.

9-speed Automatic Gearbox

The class-leading 9-speed automatic gearbox in the Jeep Compass Trailhawk® ensures effortless gear shifts and seamless power delivery. The gearbox houses a host of shorter, mid-range gears that ensure short transitions between gears for smooth and virtually unnoticeable conversions. These shorter steps between gears - thanks to being more - translate to extremely manageable, shudder-free gear shifts and enhances the vibration characteristics. In short, the 9-speed automatic gearbox will keep you in the optimum gear as you confidently drive through the world's vast unknowns.



A 4x4 WITH PUNCH.

Jeep® 4x4 Systems

The Jeep® Brand is a pioneer when it comes to 4x4 technology and our authentic engineering powers some of the best off-road machines on the planet. The Jeep® Compass Trailhawk® comes with two legendary 4x4 systems to help you find your own way up, down, through, and around almost anything.

Jeep® Active Drive system, under normal conditions, sends all available power to all the wheels while monitoring the speed of the front and rear axles. If the system detects that the front axle is moving faster than the rear axle, the Power Transfer Unit recalculates the power to be distributed to the rear axle and ensures they're both moving at the same speed.

Jeep® Active Drive Low, exclusively available in the Trailhawk®, adds a selectable low range via a final drive ratio of 4.334 and affords a greater possible crawl ratio of 20:1. This allows for enhanced climbing ability and ease of navigation in severe off-road conditions. Working in conjunction with the Selec-Terrain® system, Jeep® Active Drive Low aggressively modifies torque distribution while monitoring the engine, transmission, and Electronic Stability Control system. It uses every bit of power the engine generates to help you crawl uphill, and over large rocks and boulders bringing true off-road Trail Rated® capability within an architecture that supports fuel economy.

The Jeep® Compass Trailhawk® comes with more than 75 years of 4x4 expertise to help you tackle everything nature sends your way.

4x4 Selec-Terrain® Dial

Combined with the 4x4 systems, the Jeep® Selec-Terrain® Dial gives you best-in-class off-roading capability. The Selec-Terrain® Dial allows you to select the desired terrain setting from Auto, Snow, Sand, Mud, and Rock modes. The Jeep® Compass Trailhawk® comes with an exclusive Rock Mode, for unsurpassed control and capability on the toughest terrains. For even greater Trail Rated® off-road performance, Selec-Terrain® includes Selec-Speed Control, exclusively on Trailhawk® models, along with Hill Descent Control.



Hill Descent Control

Hill Descent Control in the Jeep Compass Trailhawk® assists you by intricately managing throttle and braking to maintain a constant, steady speed while descending slopes. This feature activates front and rear brakes while going down a slope to limit vehicle speed to a preset value, helping you descend safely without any driver input.

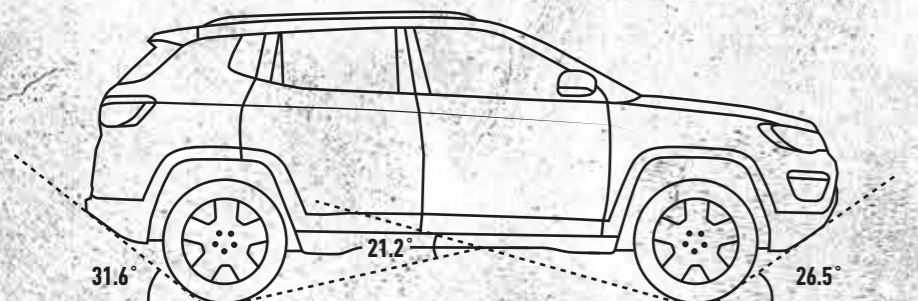

Superior Approach and Departure Angles

With an approach angle of 26.5 degrees and a departure angle of 31.6 degrees, the Jeep Compass Trailhawk® gives you the freedom to go through deeper ditches and over taller boulders. The breakover angle of 21.2 degrees ensures nothing can come in contact with its underbody while driving over sharp ridges. In other words, now you can truly "Go Anywhere, Do Anything". The enhanced suspension adjusts the wheels to ensure all of them are in contact with the surface, at all times.

Enhanced Independent Suspension with Frequency Selective Damping

The fully independent suspension of the Jeep Compass Trailhawk® delivers superior on-road driving dynamics. The exclusive long travel telescopic structure combined with the smart Frequency Selective Damping (FSD) system and precise electric power steering make for the smoothest drive on any surface. The long travel of the suspension allows for greater wheel travel and the ability to traverse over any terrain (rocks, mud, sand, and snow). The FSD actively manages bumps on your way by intelligently adjusting suspension to keep the vehicle comfortable on the inside and grounded on the outside.

Body and Chassis Strength

The Jeep Compass Trailhawk® delivers peace of mind with a hero's heart – a strong unibody structure engineered with more than 70% hot-stamped steel. Its chassis is solid and sturdy enough to ensure safe drives for years, even on the toughest terrains.

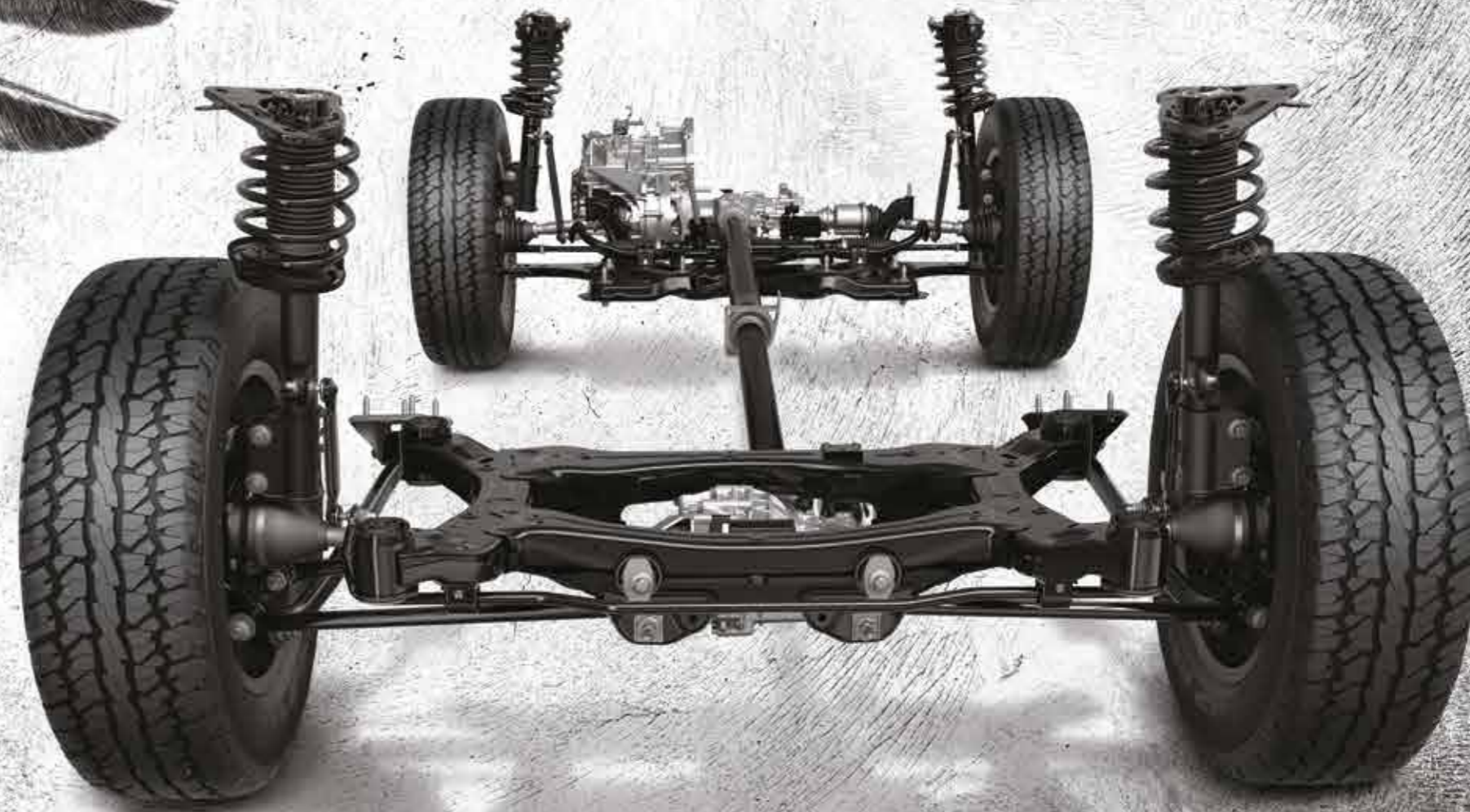



Voice and Touch Interaction

Uconnect® technology takes a leap forward with a smarter interface. It simplifies life by giving you a choice in the way you interact with your Jeep Compass Trailhawk®. Now set cabin temperature, control air flow, and operate the infotainment system by simply using voice commands or at the touch of a fingertip. While driving, you can also listen to directions via the in-built navigation app, or your music via USB Port, Audio Jack, and Bluetooth® Streaming Audio. So now you can get things done in an instant using both, voice and touch.



Smartphone Integration

Apple CarPlay® and Android Auto™ are available to cast your phone's familiar interface onto your Uconnect® touchscreen, for a safer and smarter experience. Seamlessly integrate your phone to use its features, including voice recognition, making calls, accessing music, sending and receiving messages, and getting directions optimized to traffic conditions. You can also pair up to eight Bluetooth®-enabled phones. The Do Not Disturb feature allows you to see a visual prompt of incoming calls or texts and send an automated reply.



OUTSMART EVERY JUNGLE.

Just like the Jeep Compass Trailhawk® is built to be strong, it's also designed to be smarter with the help of modern technology. Uconnect® brings a wide range of communication and entertainment services to your Trailhawk®, all bundled within a robust system. Now, enjoy the freedom of having the things you need at an arm's length.





Integrated Voice Command with Bluetooth®

The Jeep Compass Trailhawk® connects to Bluetooth®-compatible smartphones and allows you to safely send, reply to, or listen to a text, take or make phone calls, use voice commands to select music stations, set cabin temperatures, and more while keeping both hands on the wheel.

Advanced Cruise Control

Driving on highway stretches for long hours can be physically demanding and cause fatigue and soreness. The Advanced Cruise Control system conveniently allows you to lock on a specific speed and take your foot off the pedal, taking some strain away and helping you rest your legs.



THE FREEDOM TO DO MORE.

Life can go in all kinds of directions. And you need space for the company as well as the cargo. The configurable interior of the Trailhawk® is designed to give you options to take everything you need and make the most of your travels.

60/40 Split-folding Rear Seats

Configure your interior to fit your needs – rearrange by flipping either section of the 60/40 split and leave the remaining section up for passenger use.



Glove Box and Centre Console

The deep centre console offers plenty of room for items like sunglasses or small tablets. A small tray in front of the gear shifter conveniently holds phones or MP3 players, and a side net pocket for those easy-to-reach extras, while the glove box is large enough to keep your things accessible and secure.

SAFETY WHERE IT MATTERS. ALL AROUND YOU.

A hawk's nest with its brood inside is strictly a no-fly zone for other birds. Because the parental instinct in raptors is so strong that they protect their young ones at every cost. In the same way, the Jeep® Compass Trailhawk® comes with over 50 safety and security features to protect you round the clock. These active and passive safety systems give you an exceptional toolkit of confidence to go on any adventure you want and come back safely.

Parksense Rear Park Assist System

The Jeep® Compass Trailhawk® can help you park and reverse with ease. This system uses rear ultrasonic sensors to determine relative distance to objects in your back-up pathway and notifies you of rear object proximity in the Driver Information Display.

Parkview Rear Back-up Camera with Dynamic Grid Lines

Reverse in and out of your parking spot safely and with grace. This system helps bring previously hidden rear objects to your attention, either on-screen or with an audible warning, giving you enough time to react.



Electronic Parking Brake

A push-button Electronic Parking Brake eliminates traditional pull park brake systems. This premium feature functions in the following modes: Static Apply and Release, Automatic Drive Away Release, Safe Hold, and Auto Apply. You can customize the Auto Apply feature which adds an additional measure of safety, setting the Trailhawk® to automatically apply EPB on parking or in the "key off" position. When you turn on the vehicle and drive, the EPB releases automatically.

Antilock Brake System

Next-generation engineering allows this advanced system to continually evaluate road conditions for optimal engagement and stopping distances. This robust system includes Rain Brake Support, Hill Start Assist, and All-speed Grip Control, all working together to help maintain vehicle control during emergency braking.

Underbody Protection

The underbody comes with a special off-road package on the Trailhawk including skid plates for the cooling module, engine and transmission oil pans, front suspension, and fuel tanks. Every element is constructed using high-grade, heavy-duty steel and painted with a high-quality black e-coat for protection while driving off the beaten path.

Zinc-coated Steel Body for Enhanced Corrosion Protection

The steel body is coated with a protective layer of hot-dipped galvanised zinc to prevent corrosive substances from reaching the underlying steel. The zinc coating protects the steel body by slowly corroding first. However, the corrosion of zinc takes place after decades of constant exposure to corrosive substances, so you can rest assured because the Jeep Compass Trailhawk® is built to be strong on every front.

Remote Proximity Keyless Entry

Keyless Enter 'n Go automatically unlocks the door upon grabbing the handle, provided the key fob is near your vehicle. Press a small button on either front door to lock all doors.

6 Air Bags

Full-length side-curtain, front and rear-passengers, seat-mounted side for front occupants, driver single-stage, and front passenger dual-stage air bags, all help surround you with safety and confidence.



Hill Start Assist

Hill Start Assist helps prevent the Trailhawk® from rolling backwards when starting on an uphill gradient. It holds the vehicle stationary for approximately one second after your foot is removed from the brake pedal, giving you time to apply the throttle.

Electronic Roll Mitigation (ERM)

As an extension of Electronic Stability Control, Electronic Roll Mitigation uses sensors to anticipate potential risk situations. If things get rough, ERM takes immediate action to help you maintain control and stability.

Electronic Stability Control (ESC)

A vehicle-wide network of safety sensors provide instant aid should they detect the vehicle veering off your intended path. ESC coordinates Electronic Roll Mitigation, Hill Start Assist, Antilock Brake System, and all-speed grip control, sending them into action when needed, keeping you safely in the drive line.

TECHNICAL SPECIFICATIONS

Powertrain	
Engine	2.0 L Multijet II Turbo Diesel (BSVI Compliant)
Displacement	1956
Transmission	9AT (9-speed Automatic)
Max Power	170 HP @ 3750 ± 50 rpm
Torque	350 Nm @ 1750 - 2500 rpm
Dimensions	
Length	4398 mm
Width	1818 mm
Height	1657 mm
Wheelbase	2636 mm
Fuel Tank Capacity (L)	60 L
Brakes	
Front	Disc
Back	Disc
Suspension	
Front	McPherson Strut with Lower Control Arm
Back	Multi-link Suspension with Strut Assembly

Key Features

Capability

Select-Terrain® System With Auto, Snow, Sand, Mud, and Rock Modes
 Jeep® Active Drive
 All-season (All-terrain) Tyres
 Frequency Selective Damping Suspension
 Dynamic Steering Torque (DST)
 Hill Descent Control
 Engine Stop-Start (ESS) System
 Cruise Control/Speed Control
 Trailhawk® Badge

Safety

Electronic Parking Brake
 Side Air bags
 All-row Full-length Side-curtain Air bags
 All-speed Traction Control System (TCS)
 Electronic Stability Control (ESC)
 Antilock Brake System (ABS) with Electronic Brake Distribution
 Child Seat Anchors - ISOFIX
 Cornering Fog Lamps
 Rear Fog Lamps
 Electronic Roll Mitigation
 Hill Start Assist
 Hill Hold Assist
 Rear Wiper and Defogger
 4 Disc Brakes

Interior

Customisable 17.75 cm (7) Graphic Driver Information Display
 Premium Black Leather with Ruby Red Stitching
 Leather-wrapped Steering Wheel
 Power Adjustable and Folding Door Mirrors
 Push Button Engine Start
 Rear Parcel Shelf

Exterior

Seven Slot Grille with Matte Grey Surrounds
 Dual Pane Panoramic Sunroof (Optional)
 Bi-Xenon High Intensity Discharge Headlamps
 LED Taillamps
 Daytime Running Lamps
 43.18 cm (R17) Alloy Wheels with All Terrain Capabilities
 Passive Entry, Keyless Go
 Reverse Park Assist Sensors
 Reverse Parking Camera
 Door Scuff Plates

Infotainment

Uconnect® with 21.3 cm (8.4) Touchscreen Display
 Auto AC Control on Touchscreen (Integrated Center Stack)
 Integrated Voice Command
 Bluetooth® Audio Streaming
 Navigation (In-built)
 *Android Auto™ and Apple CarPlay®
 6 Speakers

Colour Options



Exotica Red



Vocal White



Minimal Grey



Magnesium Grey



Brilliant Black

SIGN UP FOR THE JEEP® LIFE.



When you buy a Jeep vehicle, you enter the Jeep life – a life of adventure, one in sync with nature. That's why, the Jeep Brand organizes Jeep Trails where Jeep owners come together to explore uncharted territories, amidst wilderness, bonfires, and much more.



Camp Jeep, is yet another unique opportunity for Jeep owners to meet new people, have fun, and go on memorable adventures. Every year, Camp Jeep, lines up an activity-packed program, featuring off-road test drives, theoretical and practical courses, and many other open-air activities.

#MyJeepStory

Every Jeep owner shares a special bond with their Jeep vehicle. From the first time they drove the vehicle to when they realized what it's truly capable of, a Jeep owner's life is filled with stories. My Jeep Story brings forward these stories of how their Jeep vehicle inspires them, how it drives them, and how it all began.



Never too far.

Our pan-India aftersales service provided through the world-renowned Mopar brand ensures that you and your Jeep Compass Trailhawk® will never be far from expert care. So, be it a change of parts, a performance upgrade, or a makeover through cosmetic accessories, our experts will always answer the call.

Helpline no. 1800 266 5337

On the same road.

In case you face any untoward situation on the road, you can simply hand over the wheel to our Mopar Roadside Assistance and leave the rest to us.

- Unlimited towing support
- Passenger travel assistance
- Accessible through the Mopar RSA app

Helpline no. 1800 209 3428

Peace of mind.

You can now ensure your Jeep Compass Trailhawk® is completely taken care of with our special Mopar Program. The Mopar extended warranty program provides an additional warranty for 2 years or 50,000 kilometers while our Mopar maintenance program covers maintenance for 5 years.



**CARE
24x7**



**EXTENDED
WARRANTY
PROGRAM**



ASSISTANCE. ALWAYS JUST ONE CALL AWAY.



Products and services:

Mopar Assure

A premium insurance product backed by prime insurance companies with a number of add-on coverages.

Mopar Tyre Care and Mopar Battery Care

A one-stop shop for all your tyre and battery needs. Mopar tyre care offers unconditional warranty for your Jeep Compass Trailhawk® tyres.

Mopar Genuine Parts

Mopar Accessories and Merchandise

Mopar Car Care

Mopar-approved car detailing products designed and developed for your Jeep Compass Trailhawk®.

With a range of products and services to cater to the people who drive us, Mopar is ready to serve you and your Jeep vehicle as the most reliable service partner you will ever find.

Jeep is a registered trademark of FCA US LLC. FCA India Automobiles Private Limited ("FCAIAPL") reserves the right to change without notice the colours, equipment specifications and models. Accessories shown in the pictures and features mentioned may not be a part of the standard equipment and could differ with variants. Actual colour of the vehicle and upholstery might differ. The Android Auto™ and Apple CarPlay™ technologies require a mobile phone equipped with the Bluetooth® Hands-Free Profile. The map is not to scale and is for representation purpose only.

Jeep[®]

Jeep[®] is a registered trademark of FCA US LLC.

Follow us on     /jeepindia | Toll free No.: 1800-266-5337 | www.jeep-india.com