

 **MARUTI SUZUKI** ARENA

 **MARUTI SUZUKI** ARENA

Maruti Suzuki India Limited
Plot No. 1, Nelson Mandela Road,
Vasant Kunj, New Delhi-110070, INDIA



The Next-Gen
ERTIGA



Designed *for* **style.**
Driven *by* **togetherness.**

*Long adventure trips or short city runs, after-party plans or just unplanned getaways.
There are many styles to life's many journeys. But they all become stylish when you take
them together with friends. So, go ahead and explore them all in the Ertiga.*



Sculpted to _____ *stand out.*

The Ertiga flaunts a bold personality that is carved into every crease, corner and contour of its design. From the striking Projector Headlamps in the front to the 3D Tail Lamps with LEDs at the back coupled with a Floating-roof design and a stylish set of Alloy Wheels, the Ertiga is designed to always put you and your friends in the spotlight every time you drive along in style.





Chrome Studded
Front Grille



Projector
Headlamps



3D Tail Lamps
with LEDs



Style *that complements*
everyone.

Space, comfort and quality, it all comes together inside the Ertiga to give you and your friends an experience which is always enjoyable and stylish. The smart Flexi-Seating along with Third Row Recliner Seats and Second Row Air Conditioning enhance the overall in-cabin experience. The seating comes with 60:40 split in second row and 50:50 split in third row along with a host of utility spaces which ensure that there is always room for more, no matter where you go.



Third Row
Recliner Seats



Flexible
Luggage Space



Large Luggage
Compartment

More power. _____
More fun.

All New K15 Petrol Engine with Progressive Smart Hybrid Technology.

The powerful drivetrain in the Ertiga comes paired with the Progressive Smart Hybrid Technology with dual battery setup which provides Idle Start-Stop, Brake Energy Regeneration and Torque Assist functionality. Thus, ensuring an energetic driving experience for you and your friends.



All New // // //

K15 Petrol Engine with
Progressive Smart Hybrid Technology _____

The all-new K15 Petrol Engine powering the Ertiga is engineered to deliver remarkable performance while ensuring a pleasurable driving experience for all. The all-new engine is available in both manual and automatic transmission options.



All New // // //

DDiS 225 (1.5L)
Diesel Engine _____

Equipped with a new high efficiency turbocharger, the DDiS 225 Diesel Engine provides Ertiga with improved torque and increased power. It comes mated with 6-speed manual transmission for smooth driving experience.





Designed to _____
impress.

Robust, modern and expressive, the interior of the Ertiga inspires true style, thanks to its all-new Sculpted Dashboard with wooden finish crafted with high-quality materials. With added aesthetic features like Leather-wrapped Flat-bottom Steering Wheel and Interior Chrome Accents, the Ertiga offers the best in comfort and class to you and your friends.*

*Certain parts of the leather upholstery contain man-made material.



Always awesome.
Always advanced.

The Ertiga comes with a 10.67 cm TFT Multi-Information Colour Display* that makes it convenient for you to keep a track of your car's vital information. It also hosts a futuristic 17.8 cm SmartPlay Infotainment System which ensures that you and your friends are always connected and entertained through every drive.

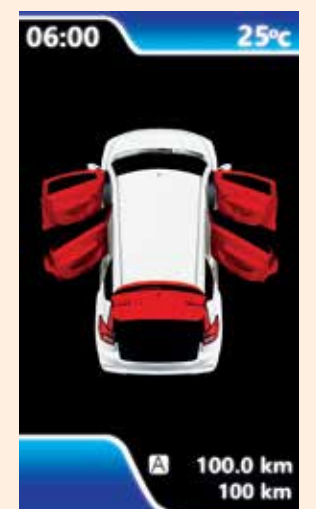

Door Open *Display*

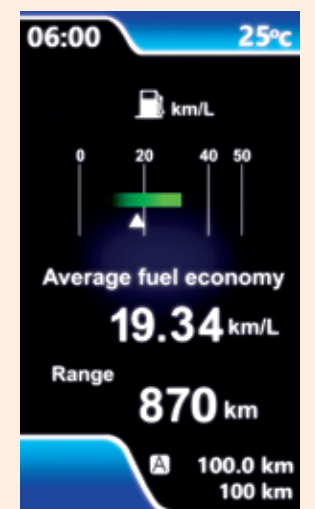

Average Fuel *Economy*



Power & *Torque*

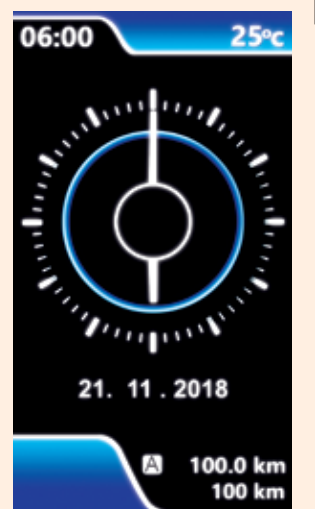

Clock

* MID coloured TFT is available in selected variants only.



SmartPlay
Infotainment System



*Apple and iPhone are trademarks of Apple Inc., registered in the U.S. and other countries.
 *Apple CarPlay is a trademark of Apple Inc. Apple CarPlay is available in the countries listed in the following link: <http://www.apple.com/ios/feature-availability/#applecarplay-applecarplay>. *Apple CarPlay is compatible with the iPhone models listed in the following link <http://www.apple.com/ios/carplay>

androidauto

Android Auto™ extends the Android platform into the car in a way that's purpose-built for driving. It is designed to minimise distraction so you can focus on driving with Google™ services like Google Maps™ and Google Search™. Get the Android Auto app on Google Play™. *Android Auto is available in the countries listed at the following link: <https://www.android.com/auto/#hit-the-road>. *Most phones with Android 5.0+ work with Android Auto: <https://support.google.com/androidauto/#6140477>. *Android, Android Auto, Google, Google Play and other marks are trademarks of Google Inc.



Steering Mounted
Audio and Calling Controls



Air Cooled
Twin Cup Holders



Automatic
Climate Control

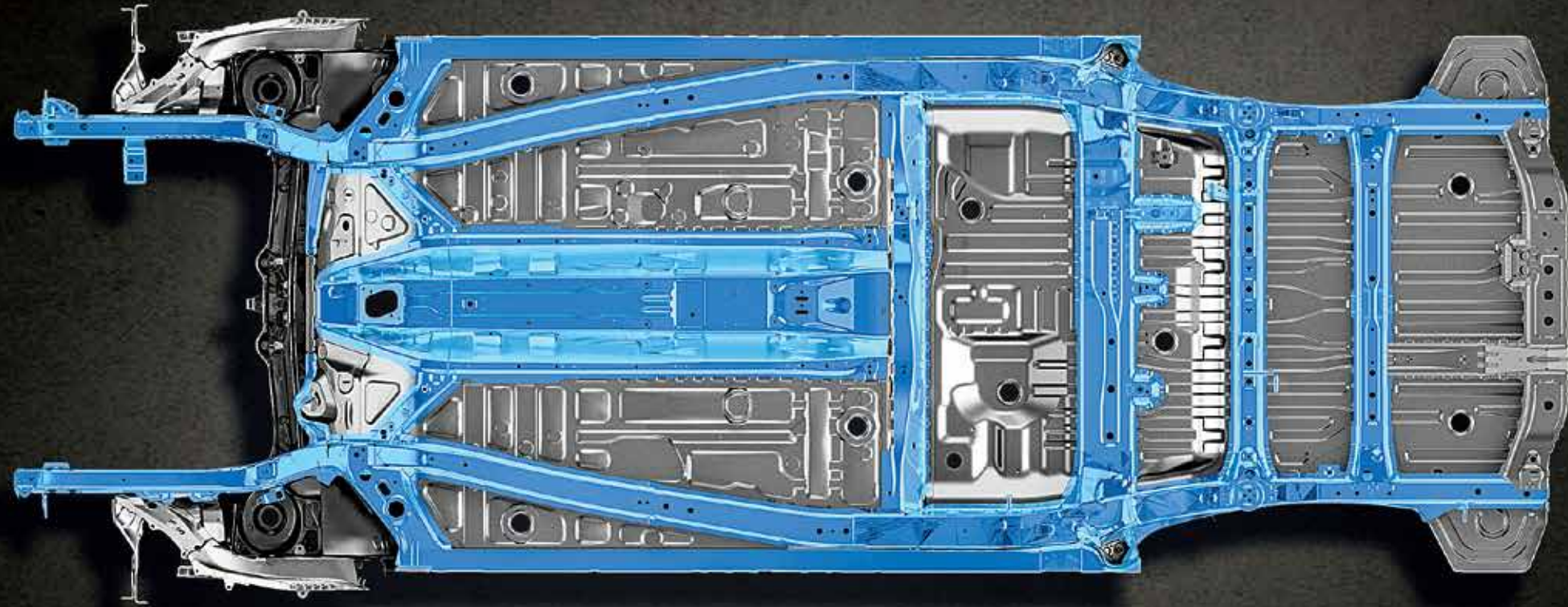

Safe in every sense.

What makes the Ertiga incredibly safe is that it is based on the solid Heartect Platform which employs high-tensile steel at all the right places to improve overall safety, rigidity and NVH performance. It is built for effective absorption and dispersion of crash energy which provides higher safety for occupants. Furthermore, the Ertiga is equipped with a host of safety features like Dual Airbags, ABS with EBD, ISOFIX Child Seat Anchorages, Reverse Parking Sensors, Front Seat Belts with Pre-tensioner and Force Limiters and Hi-speed Alert System as standard which ensure absolute safety for everyone.

Heartect
Platform



Hill Hold
Technology**



Dual
Airbags



Electronic
Stability Program**

**Available in Automatic variants only.

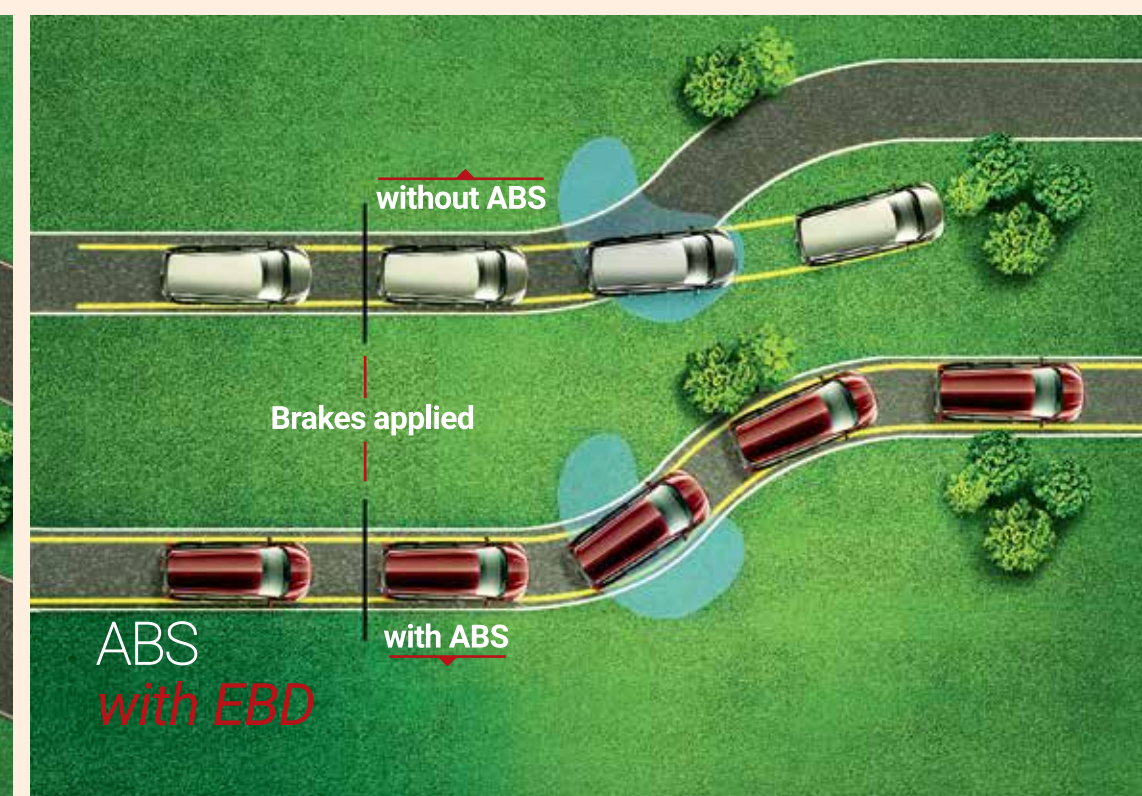

ABS
with EBD

Style comes in _____
many colours.



Pearl Metallic
Auburn Red



Pearl Metallic
Oxford Blue



Metallic
Magma Grey



Metallic
Silky Silver



Pearl
Arctic White

EQUIPMENT LIST

FEATURES & SPECIFICATIONS	VARIANTS			
	Lxi	Vxi / Vxi AT / Vdi / Vxi CNG	Zxi / Zxi AT / Zdi	Zxi+ / Zdi+
INTERIORS				
Sculpted Dashboard with Wooden Finish	-	-	✓	✓
Wooden Finish on Door Trims (Fr.)	-	-	✓	✓
Dual Tone Interiors	✓	✓	✓	✓
Height Adjustable Driver Seat	-	-	✓	✓
2nd Row Seats 60:40 Split with Slide and Recline	✓	✓	✓	✓
3rd Row Seats 50:50 Split with Recline	✓	✓	✓	✓
Sliding Armrest with Utility Box (Front Row)	-	-	✓	✓
2nd Row Armrest	-	✓	✓	✓
Leather Wrapped Steering Wheel with Wooden Finish	-	-	-	✓
Headrest Front Row Seats	✓	✓	✓	✓
Headrest 2nd Row Seats	✓	✓	✓	✓
Headrest 3rd Row Seats	✓	✓	✓	✓
Split Type Luggage Board	-	✓ (Except CNG)	✓	✓
Driver Side Sunvisor with Ticket Holder	✓	✓	✓	✓
Chrome Tipped Parking Brake Lever	-	✓	✓	✓
Gear Shift Knob with Chrome Finish	-	✓	✓	✓
INSTRUMENT CLUSTER				
MID	-	✓(Vdi / CNG)	-	-
MID With Coloured TFT	✓	✓(Petrol)	✓	✓
Tachometer	✓	✓	✓	✓
Gear Shift Indicator	✓	✓(MT Only)	✓(MT Only)	✓
Digital Clock	✓	✓	✓	✓
Outside Temperature Gauge	-	-	✓	✓
Fuel Consumption (Instantaneous and Avg)	✓	✓	✓	✓
Distance to Empty	✓	✓	✓	✓
Headlamp On Warning	✓	✓	✓	✓
Door Ajar Warning Lamp	✓	✓	✓	✓
COMFORT & CONVENIENCE				
Engine Push Start/Stop with Smart Key	-	-	✓	✓
Manual AC	✓	✓	-	-
Auto AC	-	-	✓	✓
2nd Row Adjustable AC	-	✓	✓	✓
Air Cooled Twin Cup Holder (Console)	✓	✓	✓	✓
Rear Defogger	-	-	✓	✓
Remote Keyless Entry	-	✓	✓	✓
Accessory Socket Front Row with Smartphone Storage Space	✓	✓	✓	✓
Accessory Socket 2nd Row with Smartphone Storage Space	-	✓	✓	✓
Accessory Socket 3rd Row	-	-	✓	✓
Power Windows (Fr/Rr) with Dr. side Auto Down Functions	✓	✓	✓	✓
Day & Night Adjustable IRVM	-	✓	✓	✓
Power & Tilt Steering	✓	✓	✓	✓
Electrical Adjustable ORVM	-	✓	✓	✓
Electrical Foldable ORVM	-	✓	✓	✓
Bottle Holders (in each row)	✓	✓	✓	✓
Cabin Lamp (Fr.+Rr.)	✓	✓	✓	✓
Passenger Side Sunvisor with Vanity Mirror	-	✓	✓	✓

FEATURES & SPECIFICATIONS	VARIANTS			
	Lxi	Vxi / Vxi AT / Vdi / Vxi CNG	Zxi / Zxi AT / Zdi	Zxi+ / Zdi+
INFOTAINMENT SYSTEM				
17.8 cm Touchscreen SmartPlay Infotainment System with Apple CarPlay and Android Auto Control	-	-	-	✓
Inbuilt Navigation System	-	-	-	✓
Voice Command System	-	-	-	✓
Mirror Link support for Smartphone Connectivity	-	-	-	✓
Audio System with Electrostatic Touch Buttons	-	✓	✓	-
Bluetooth Connectivity	-	✓	✓	✓
Speakers (4)	-	✓	✓	✓
Tweeters (2)	-	-	✓	✓
USB and AUX Connectivity	-	✓	✓	✓
Steering Mounted Audio Control	-	✓	✓	✓
Steering Mounted Calling Control	-	✓	✓	✓
SAFETY AND SECURITY				
Dual Airbag	✓	✓	✓	✓
ABS with EBD and Brake Assist	✓	✓	✓	✓
Engine Immobilizer	✓	✓	✓	✓
ESP	-	✓ (AT Only)	✓ (AT Only)	-
Hill Hold	-	✓ (AT Only)	✓ (AT Only)	-
ISOFIX Child Seat Anchorages (2nd Row Seats)	✓	✓	✓	✓
Front Seat Belts with Pre-tensioner & Force Limiters (Dr.+Co-Dr.)	✓	✓	✓	✓
Seat Belt Reminder Lamp with Buzzer (Dr.+Co-Dr.)	✓	✓	✓	✓
Front Seat Belt Height Adjuster	-	-	✓	✓
High Speed Alert System	✓	✓	✓	✓
Speed Sensitive Auto Door Lock	✓	✓	✓	✓
Security Alarm	-	✓	✓	✓
Rear Parking Sensors	✓	✓	✓	✓
Rear Parking Camera	-	-	-	✓
Central Locking	✓	✓	✓	✓
Front Fog Lamps	-	-	✓	✓
EXTERIOR				
Projector Headlamp (Halogen)	✓	✓	✓	✓
3D Tail Lamps with LED	✓	✓	✓	✓
Front Grille	Painted	Chrome	Chrome	Chrome
Full Wheel Caps	-	✓	-	-
Alloy Wheels	-	-	✓	✓
Turn Signal Lamp Integrated in ORVM	-	✓	✓	✓
Back Door Chrome Garnish	-	-	✓	✓
Rear Wiper & Washer	-	-	✓	✓
Body Coloured Door Handles	-	✓	-	-
Chrome Plated Door Handles	-	-	✓	✓
Body Coloured ORVM	-	✓	✓	✓

FEATURES & SPECIFICATIONS	PETROL	DIESEL	CNG
Variants	Lxi, Vxi, Vxi AT, Zxi, Zxi AT, Zxi+	Vdi, Zdi, Zdi+	Vxi
DIMENSIONS			
Length (mm)	4395		
Width (mm)	1735		
Height (mm)	1690		
Wheelbase (mm)	2740		
Turning Radius (m)	5.2		
Seating Capacity	7		
Boot Space` (L)	209(All 3 Rows Up), 550(3rd Row Folded) & 803(2nd Row and 3rd Row Folded)		-
ENGINE			
Type	K15B SMART HYBRID	DDiS 225	K15B
Capacity (cc)	1462	1498	1462
Compression Ratio	(10.5 ± 0.3):1	15.8 (+0.4/-0.3):1	(10.5 ± 0.4):1
Bore X Stroke (mm)	74.0x85.0	77.0x80.4	74.0x85.0
Power (kW@RPM)	77@6000	70@4000	77@6000 (Petrol Mode) 68@6000 (CNG Mode)
Torque (Nm@RPM)	138@4400	225@1500-2500	138@4400 (Petrol Mode) 122@4400 (CNG Mode)
Fuel Efficiency*	19.01 (MT) / 17.99(AT) km/l	24.20 km/l	26.20 km/kg (CNG Mode)
Emission Type	BS VI	BS IV	
Fuel Tank Capacity (L)	45		Petrol : 45 CNG: 60 (Water Equivalent)
DRIVE & TRANSMISSION			
Drive	2WD, FF		
Transmission	5MT / 4AT	6MT	5MT
BRAKE			
Front	(Ventilated) Disc		
Rear	(Leading & Trailing) Drum		

FEATURES & SPECIFICATIONS	PETROL	DIESEL	CNG
Variants	Lxi, Vxi, Vxi AT, Zxi, Zxi AT, Zxi+	Vdi, Zdi, Zdi+	Vxi
SUSPENSION			
Front	MacPherson Strut & Coil Spring		
Rear	Torsion Beam & Coil Spring		
Tyre Size	185/65 R15		
NEW TECHNOLOGY			
Idle Start Stop	✓	-	-
Brake Energy Regeneration	✓	-	-
Torque Assist during Acceleration	✓	-	-
WEIGHT			
Kerb Weight (kg)	1135-1170	1220-1225	1235
Gross Vehicle Weight (kg)	1730(MT), 1740(AT)	1800	1795

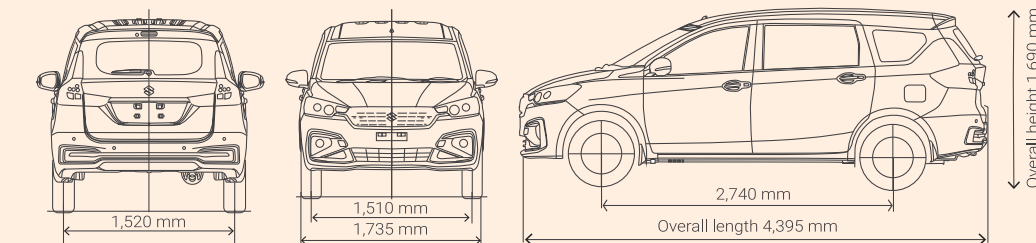

The drawings shown are general specifications of the vehicle.

**Except CNG mode.

*As certified by Test Agency Under Rule 115 of CMVR 1989.

Fr: Front; Rr: Rear; AT:Automatic Transmission; MT: Manual Transmission; MID: Multi Information Display

Maruti Suzuki India Limited reserves the right to change, without notice, price, colours, equipment specifications, and models and also to discontinue models and/or replace any part or accessory with any product. Accessory and feature shown in the pictures may not be a part of standard equipment and will differ according to the variant. Any offers made will be subject to availability of the product. For more details, contact your nearest store. Spare wheel material is steel (for all variants). *Boot space mentioned is inclusive of under luggage board space (VDA Method).

Apple and iPhone are trademarks of Apple Inc. registered in the U.S. and other countries. Apple CarPlay is a trademark of Apple Inc., Apple CarPlay is available in the countries listed in the following link: <http://www.apple.com/ios/feature-availability/#applecarplay-applecarplay>. Apple CarPlay is compatible with the iPhone models listed in the following link: <http://www.apple.com/ios/carplay>. *Android Auto™ extends the Android platform into the car in a way that's purpose-built for driving. It is designed to minimise distraction so you can focus on driving with Google™ services like Google Maps™ and Google Search™. Get the Android Auto app on Google Play™. *Android Auto is available in the countries listed at the following link: <https://www.android.com/auto/#hit-the-road>. *Most phones with Android 5.0+ work with Android Auto: <https://support.google.com/androidauto/#6140477>. *Android, Android Auto, Google, Google Play and other marks are trademarks of Google Inc. Image used are for illustration purposes only. The speed alert system gives audible warning for alert of over-speed to driver. When vehicle speed exceeds about 80 km/h, primary level warning with two beeps will sound every minute. When the vehicle speed exceeds about 120 km/h, secondary level warning with continuous beeps will sound. If the vehicle speed is slowed down to about 118 km/h, primary warning will resume. If the vehicle is slowed down to about 78 km/h, speed alert warning will stop. This buzzer does not indicate any malfunction in vehicle.